



ecoStorm plus 400 roof/traffic

– Stormwater Filtration System

For the removal of sediments,
heavy metals and nutrients.

ecoStorm
plus

**under the license of Hydrocon*

Stormwater Filtration is vital to maintaining the quality of our finite water supply.



ecoStorm plus 400

ecoTECHNIC presents ecoStorm plus, an affordable stormwater filtration system designed to remove sediments, heavy metals and nutrients.

Surface water runoff contains significant concentrations of heavy metals and other soluble pollutants. Structural Stormwater treatment systems are effective in removing sediments, but do not remove solubles such as heavy metals and nutrients (phosphates and nitrates).

By using various physical and chemical processes, the ecoStorm plus Filtration System effectively AND affordably removes BOTH solids and dissolved substances, including:

- Heavy metals (zinc, copper, lead, cadmium, chromium, nickel)
- Hydrocarbons (mineral oils, polycyclic aromatic hydrocarbons)
- Nutrients such as phosphorous and nitrates

Removal Efficiency*

Removal efficiencies for all relevant pollutants far exceed both North American and European Standards for stormwater run-off.

Total Suspended Solids (TSS)	>95%
Zinc (Zn)	>80%
Lead (Pb)	>95%
Copper (Cu)	>90%
Hydrocarbons	>98%
Phosphorous	>70%
Nitrates	*

* detailed test reports are available upon request

See why ecoStorm plus is the most cost effective stormwater filtration system on the market, setting new standards for stormwater regulatory requirements.

- In addition to filtration, the system utilizes chemical transformation, precipitation and sorption (ion exchange) to remove a variety of pollutants (heavy metals, hydrocarbons) from stormwater
- More effective and affordable than conventional filters utilizing stainless steel, activated carbon or zeolites
- Upstream sediment removal combined with self-cleaning filters reduces maintenance intervals and costs
- Easy installation saves time and money — single-structure design comes pre-assembled to jobsite, reducing footprint and excavation costs
- Has undergone extensive laboratory and field-testing with proven results
- Patented concrete filters can be modified to accommodate various applications and flowrates

ecoStorm plus is ideal for new construction or retrofit applications including:

- Parking lots
- Treatment of run-off from metal roofs (Copper, Zinc and others)
- Industrial manufacturing facilities
- Commercial/retail developments
- Municipal/residential drainage improvements
- Transportation/maintenance facilities
- Water quality improvement of ponds and lakes

ecoStorm plus Treatment Process

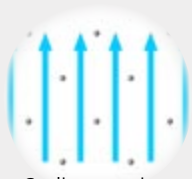

Sedimentation

All ecoStorm plus units are equipped with a central overflow and maintenance pipe to handle peak flow rates and allow access to the sediment storage chamber. While ecoStorm plus is typically designed for gravity treatment of stormwater drainage, it has the flexibility to accommodate other methods of pollutant delivery. The patented concrete filters can be modified to accommodate various applications and flowrates.

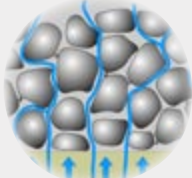

Filtration

Sedimentation

Sediments are removed from stormwater by gravitation and trapped in the base section of the ecoStorm plus unit. A small amount of sediment will accumulate temporarily on the lower surface of the filter (PlusFilter). The design of the ecoStorm plus system allows self cleaning.

Filtration

Vertical filtration in the pollution control pit and constant immersion in water of the PlusFilter prevents formation of a film on the lower side of the filter, which might otherwise lead to clogging.

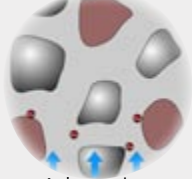

Adsorption

Adsorption

Pollutants like hydrocarbons and dissolved heavy metals are adsorbed by the modified porous concrete surface.

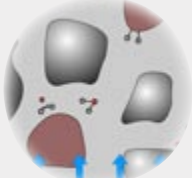

Precipitation

Chemical precipitation

The PlusFilter buffers the pH of the stormwater, which is typically acidic, hence promoting precipitation and accumulation of dissolved substances. The fine pores of the filter allow water to seep slowly through the media providing greater opportunity for interaction between water and the alkaline composition of the filter.

Specifically designed for low-cost and easy maintenance.



The frequency of sediment removal and filter replacement are dependent on site-conditions and pollutant loads. Sediment, which may contain heavy metals removed during the cleaning process, is disposed either manually or by mechanical suction. Permeable concrete filters (PlusFilter) in the Pollution Control Pit are self-cleaning and are expected to remain effective for long periods (up to 2 years) without replacement. However, new filters should be considered at more frequent intervals where pollution loads are heavy. Replacing filters is an easy and inexpensive process.

Designed for a variety of applications.

- Treatment of run-off from metal roofs
- Surface water runoff from streets, highways and parking lots
- Upstream to a rainwater harvesting tank.
- Stormwater runoff from surface areas generating less than 50gpm (3l/s) treatment flow rate.



ecoStorm plus 400 working principle:

1. The rainwater from the connected area is fed into the base section of the filter housing. The tangential inlet generates a radial flow pattern.

2. The hydrodynamic separator converts turbulent waters into a radial laminar flow pattern, generating particle sedimentation, particularly of the sand fraction.

3. This takes place over an inlet to the lower section of the filter shaft. The sediment is retained in a sediment storage chamber below the separator. The sediment trap can be withdrawn for cleaning, and has an integral cleaning port to the side to ease dirt removal, (see 4)

4. In the central section of the filter housing is the actual filter, Filter Roof. The filter element filters out the fine materials in an up-flow process and dissolved materials are precipitated and adsorbed. The filter is backwashed from above. When exhausted the filter is easily exchanged.

5. The filter element is easily pulled up and removed from the shaft housing.

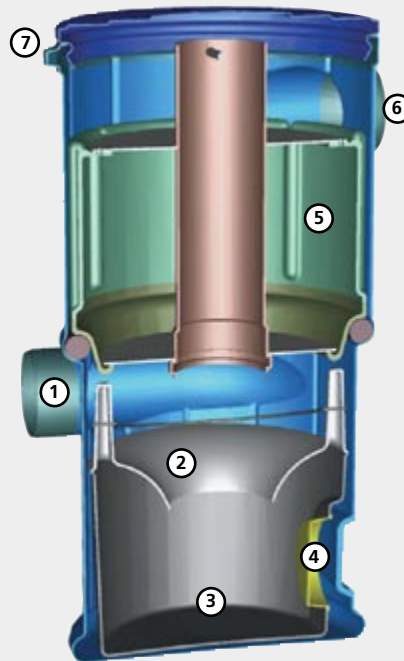

1. Rainwater Inlet
2. Hydrodynamic Separator
3. Sediment collection chamber
4. Cleaning port for sediments
5. Filter Element with overflow pipe and removal handle
6. Outlet to rainwater tank and or soakaway system
7. Bayonet Fitting lugs for fitting telescopic extensions

ecoStorm plus 400 technical data:

ecoStorm plus 400 roof/traffic (item no. 103087)

Designed to treat roof runoff from smaller areas (100 to 175m² depending on rainfall intensity). Can be installed directly in the ground without any additional concrete manhole.

Treatment flow rate: 3 l/s (50 gpm)

Pipe dimensions: DN 100mm (4")

Number of Filter segments: 1

Material: HDPE

Weight: 21 kg

Dimensions: D=440 mm, H=930-1430 mm

Telescopic Extension (item no. 100951)

Plastic telescopic extension shaft for installation direct in the ground.

Material: Polyethylene.

Replacement filter (item no. 103088)

For the ecoStorm plus 400 roof/traffic.

Filter Element should be checked every 2 years and should be changed if necessary.

